

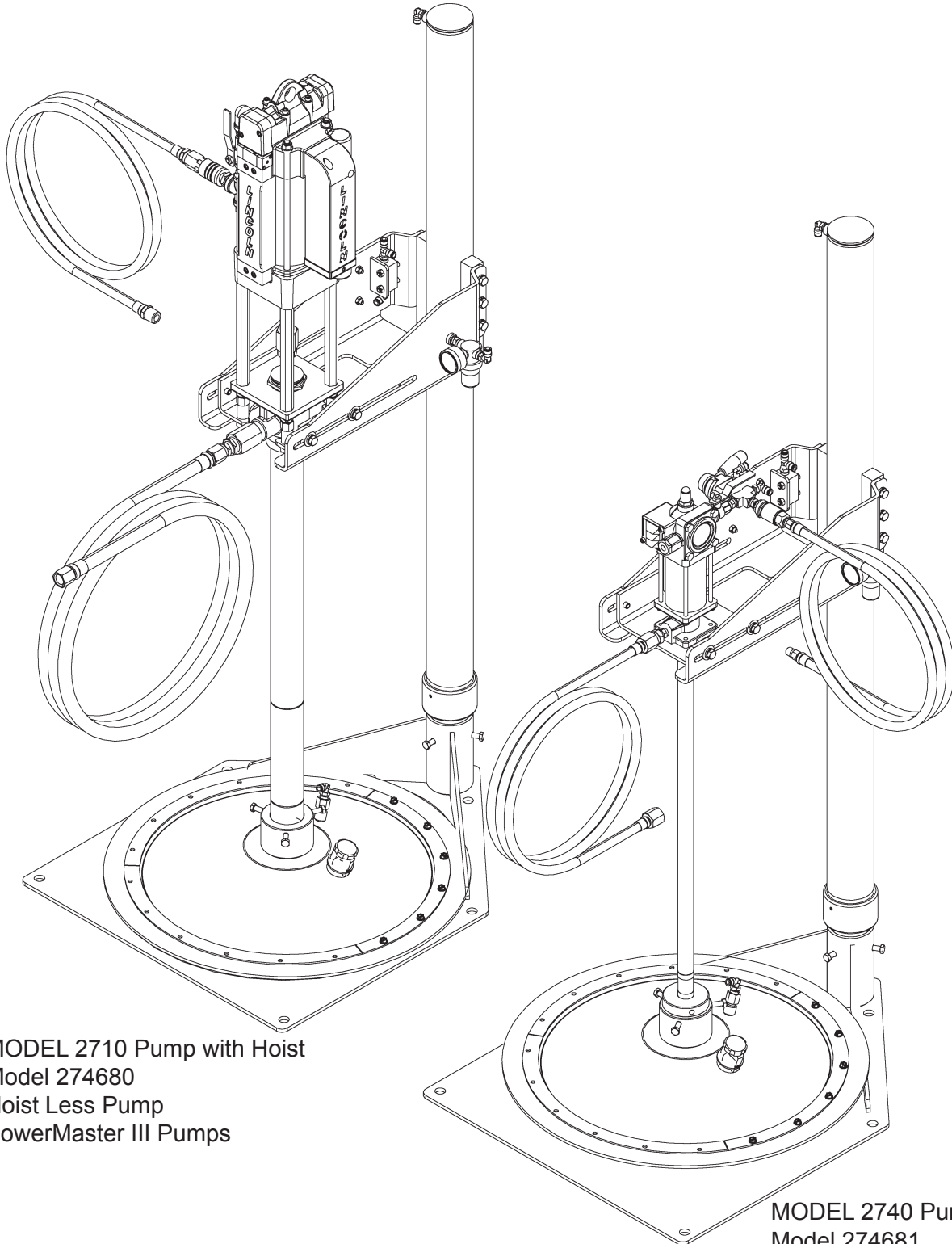

MODEL NOS. 2710 & 2740
PUMP & HOIST ASS'Y
MODEL NOS. 274680 & 274681
400 LB. DRUM SIZE AIR OPERATED,
MANUALLY CONTROLLED
Series "A"



MODEL 2710 Pump with Hoist
Model 274680
Hoist Less Pump
PowerMaster III Pumps

MODEL 2740 Pumpw/Hoist
Model 274681
Hoist Less Pump
Series 40 Pumps

**MODEL NOS. 2710 & 2740
PUMP & HOIST ASS'Y
MODEL NOS. 274680 & 274681
400 LB. DRUM SIZE AIR OPERATED, MANUALLY CONTROLLED**



MODEL 2710 (274680)

SPECIFICATIONS:

UNIT HEIGHT LOWERED POSITION: 62-9/16"
UNIT HEIGHT RAISED POSITION: 103"
HOIST CAPACITY: 200 LBS
OPERATING AIR PRESSURE, HOIST: 40-100 PSI
AIR MOTOR: 84804
PUMP TUBE: 84995
PUMP RATIO: 50:1
PUMP MAX WORKING PRESSURE: 4000 PSI
(LIMITED BY
HOSE
WORKING
PRESSURE)
PUMP MAX AIR PRESSURE: 80 PSI
AIR INLET: 1/2 NPT MALE
(1/2 ID HOSE)
LUBE OUTLET: 1/2 NPT
FEMALE X 84"
(3/8 ID SAE
100R2) HOSE

MODEL 2740 (274681)

SPECIFICATIONS:

UNIT HEIGHT LOWERED POSITION: 60-1/4"
UNIT HEIGHT RAISED POSITION: 97"
HOIST CAPACITY: 200 LBS
OPERATING AIR PRESSURE, HOIST: 40-100 PSI
PUMP: 84668
PUMP RATIO: 50:1
PUMP MAX WORKING PRESSURE: 5000 PSI
(LIMITED BY
HOSE
WORKING
PRESSURE)
PUMP MAX AIR PRESSURE: 100 PSI
AIR INLET: 1/4 NPT MALE
(1/4 ID HOSE)
LUBE OUTLET: 1/4 NPT MALE X
84" (1/4 ID SAE
100R2) HOSE

DESCRIPTION:

Model 2710 consists of a pump hoist for use with 400# refinery container drums, 400# follower, Powermaster III pump tube, air motor, and the necessary hoses and fittings to perform a basic installation. (See Illustration 1.)

Model 2740 consists of a pump hoist for use with 400# refinery container drums, 400# follower, Series 40 pump, and the necessary hoses and fittings to perform a basic installation. (See Illustration 2.)

Model 274680 is a basic pump hoist assembly, less pump, for use with Powermaster III pump tubes and air motors. The 400# follower, hoses and necessary fittings are included.

Model 274681 is a basic pump hoist assembly, less pump, for use with Series 40 pumps. The 400# follower, hoses and necessary fittings are included.

All models are designed to hold a pump and follower in position for insertion into a standard 400# refinery container. The priming action of this unit is created by gravity and the vacuum created when material is removed from the drum by the pump. No force by the hoist is used to cause a priming action to the pump. The follower will remain on top of the lubricant until the container is emptied by the pump. The action of gravity and atmospheric pressure acting on the follower will cause the priming action, directing material into the inlet of the pump tube.

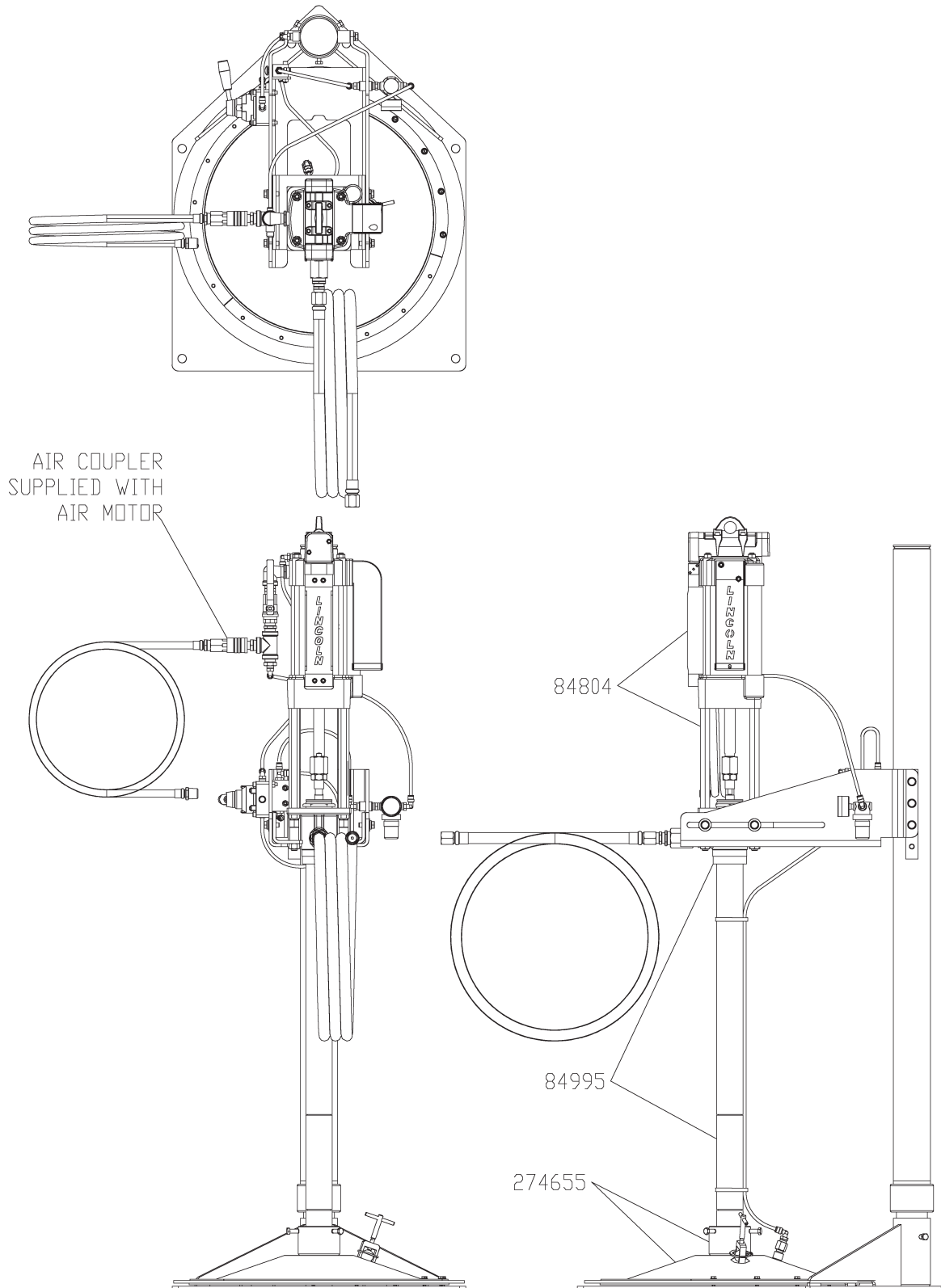

Illustration 1

MODEL NOS. 2710 & 2740
PUMP & HOIST ASS'Y
MODEL NOS. 274680 & 274681
400 LB. DRUM SIZE AIR OPERATED, MANUALLY CONTROLLED

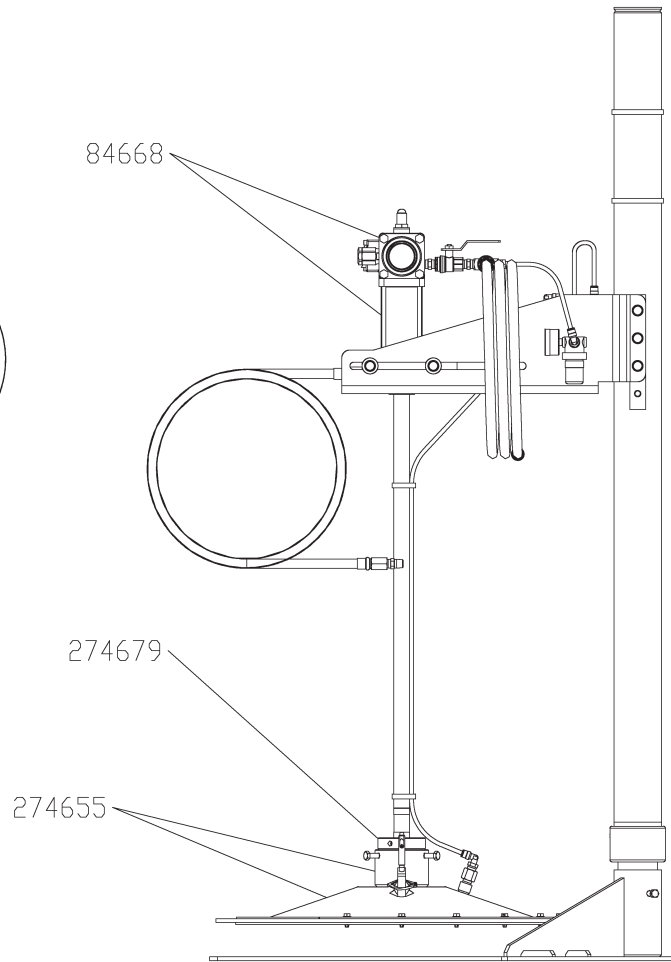
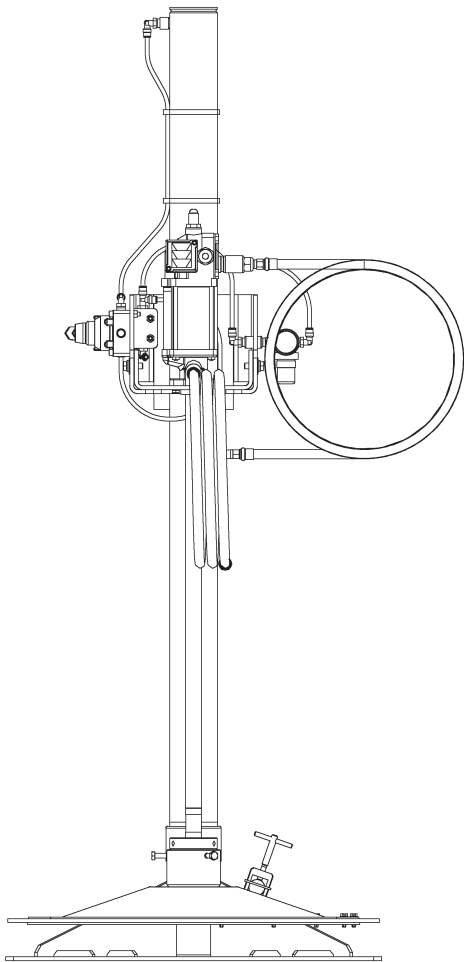
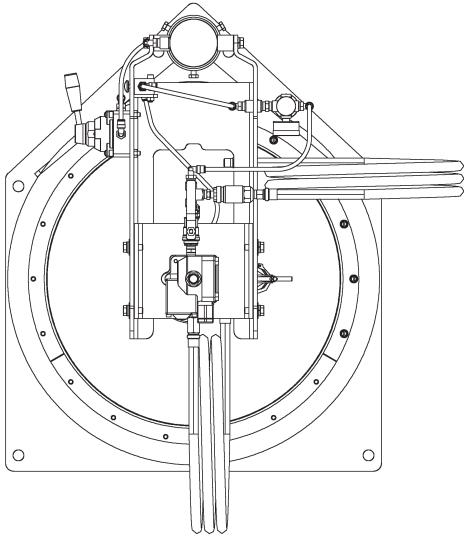

Illustration 2

INSTALLATION:

1. Select a location where there is adequate clearance around the hoist to operate and maneuver around the hoist and pump assembly when installing and removing drums.
2. The mounting base must be securely fastened to the floor before use. Mounting dimensions are provided on Base Mounting Dimensions illustration (See Illustration 3), or the base may be used as a template for drilling and positioning anchors.

WARNING

Failure to securely fasten the base to the floor may result in severe injury and or property damage. Pump hoist may topple over if not securely fastened.

3. After hoist has been secured to the floor adjust the pump support, item 56, so that it is parallel to the floor. This will keep the pump tube parallel with the support tube.
4. Mount pump to pump mount (item 29 or 53) depending on model.
When attaching the Series 40 pumps to the mount, (item 53), attach pump outlet body to pump mount with four 1/4-20 x 9/16 hex screw and washer assemblies, item 54. See Series 40 Assembly Details.
When attaching the Power Master Pump to the mount, item 29, use four extension adapters, item 40. See Power Master III Assembly Details. Note that the extension adapters are threaded onto the pump tie rods against the tie rod nuts, as shown in the illustration.
5. Place pump and mount into pump support, item 56, and loosely install hex bolts, lock washers, and flat washers, items 4, 5, & 6, through slots in support. Leave loose until final adjustment is made.
6. Assemble air inlet fittings as shown in the appropriate assembly detail page for the model that is being assembled. Assemble the air regulator, item 44, to the air inlet of the hoist as shown in the illustration. Note that there is a 1/8 pipe plug packaged with each regulator for plugging the unused gage port in the regulator.
7. After all fittings are assembled and tight measure and cut a length of 1/4 OD black polyurethane tubing, supplied, to connect the air inlet to the regulator inlet as shown in the illustrations. The tubing will simply push fit into the 1/4 fittings included with the model.
8. Assemble the air hose to the air coupler as required for the model assembled. (Note that the air coupler for the Power Master Air Motor is supplied with the air motor.) Make sure the ball valve, item 35 or 45, is closed and the hoist control valve, item 10, should be placed in the down position, and attach air hose to source of filtered, regulated air. The air pressure should be set initially to about 40 PSI.
9. Adjust the hoist air regulator, item 44, for a pressure of around 30-40 PSI. Check for air leaks in all connections. Slowly move the hoist control valve, item 10, to the raised position and raise pump so the end of the pump tube will clear the primer assembly.

10. Attach the primer assembly to the end of the pump tube. When assembling the Power Master Pump tube to the follower, apply some grease to the end of the pump tube, and the O-rings inside the follower assembly. Lower the end of the pump tube into the follower until the pump tube is flush with the bottom of the follower. Tighten the three hex screws, item 24, on the follower until tight. When assembling the Series 40 pump to the follower, a reducing adapter is used, item 55. Apply some grease to the outside of the adapter and the O-rings on the inside of the adapter and the inside of the follower. Push the adapter into the follower assembly until it seats against the shoulder. Tighten the three hex bolts on the follower, item 24, securely. Apply some grease to the end of the pump tube and slide into the reducing adapter, item 55, until the pump tube is flush with the bottom of the follower. Tighten the three set screws, item 32, securely.
11. Raise the follower high enough to clear an open 400# container. Place the container under the follower and slide the drum back on the mounting base, item 8, until it is against the two gusset plates on the base. Adjust the position of the pump with respect to the drum by sliding the pump mount (item 29 or 53) in the pump support, item 56, until the follower is centered over the open drum. Tighten the hex bolts, item 4, through the slots in the pump support to secure the pump mount.
12. Using the remaining polyurethane tubing, attach to the open fitting on the 2-way air valve, item 17, mounted on the pump support, item 56, by pushing one end of the tube into the fitting until secure. Thread the tubing down along the pump tube to the fitting, item 1, in the top of the follower assembly. Secure the tubing to the pump tube with two nylon wire ties, supplied with the assembly.
13. Check for proper air flow by pressing button on 2-way air valve, item 17, making sure that air flows through check valve, item 30, and out under follower assembly.
14. Connect fluid hoses to pump outlet.
Power Master Pumps are supplied with a 3/8" ID high pressure hose with 1/2 NPT female threaded connections. Thread a 3/4 NPT x 1/2 NPT bushing adapter, item 36, into the pump outlet and tighten securely. Thread a 1/2 NPT hex nipple, item 34, into the bushing and tighten securely. Attach the high pressure hose, item 50, to the hex nipple and tighten for leak free fit.
Series 40 pumps are supplied with a 1/4" ID high pressure hose, item 52, with 33/64 female thread on both ends. Two male adapters, item 48, are supplied to adapt the hose to 1/4 NPT male for the pump outlet, and working end of the hose. Insert the hose adapters, item 48, into each end of the high pressure hose and tighten securely for leak proof seal. Thread one end of the hose into the pump outlet and tighten securely. Attach the other end as required for the application.

**MODEL NOS. 2710 & 2740
 PUMP & HOIST ASS'Y
 MODEL NOS. 274680 & 274681
 400 LB. DRUM SIZE AIR OPERATED, MANUALLY CONTROLLED**

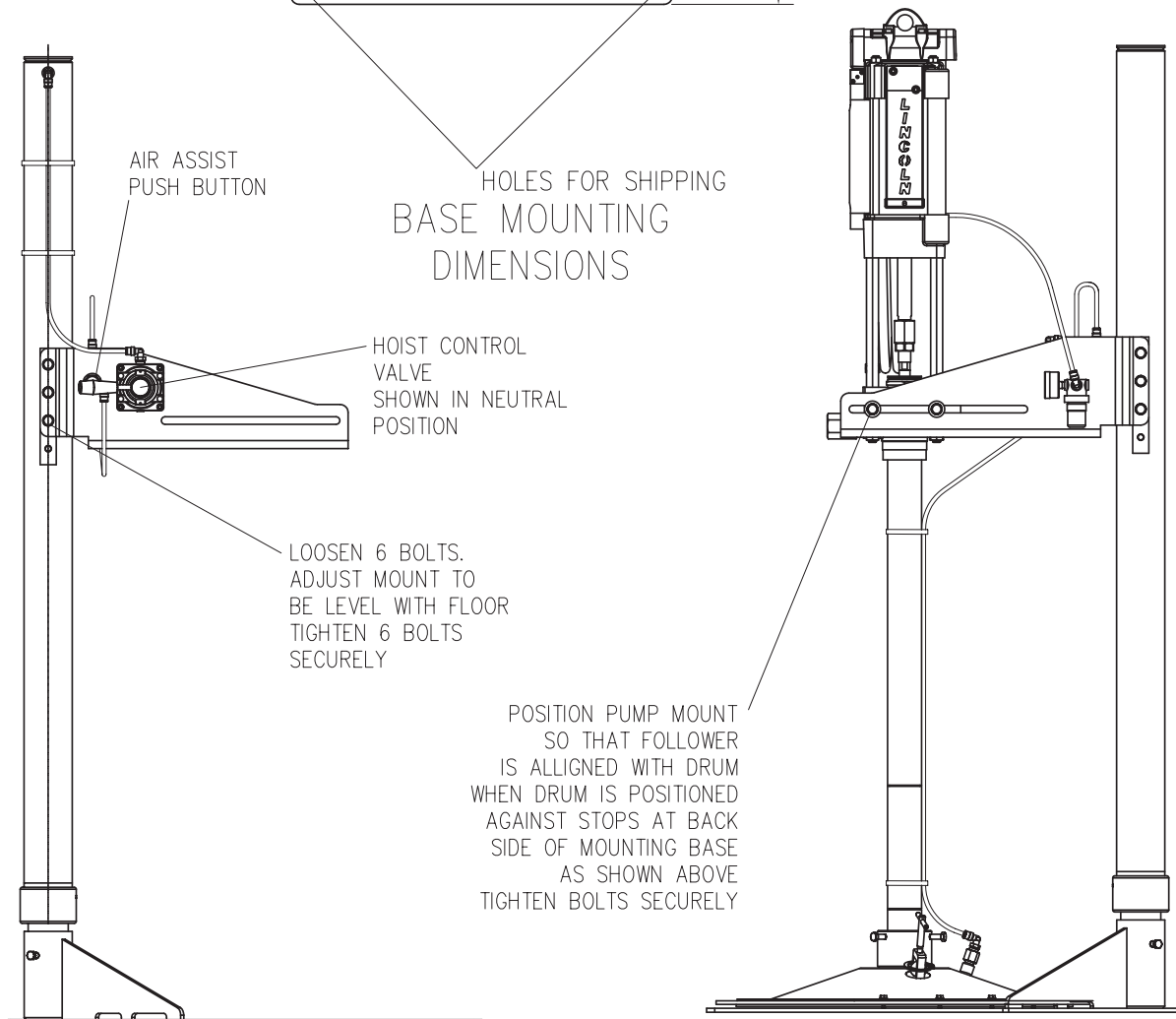
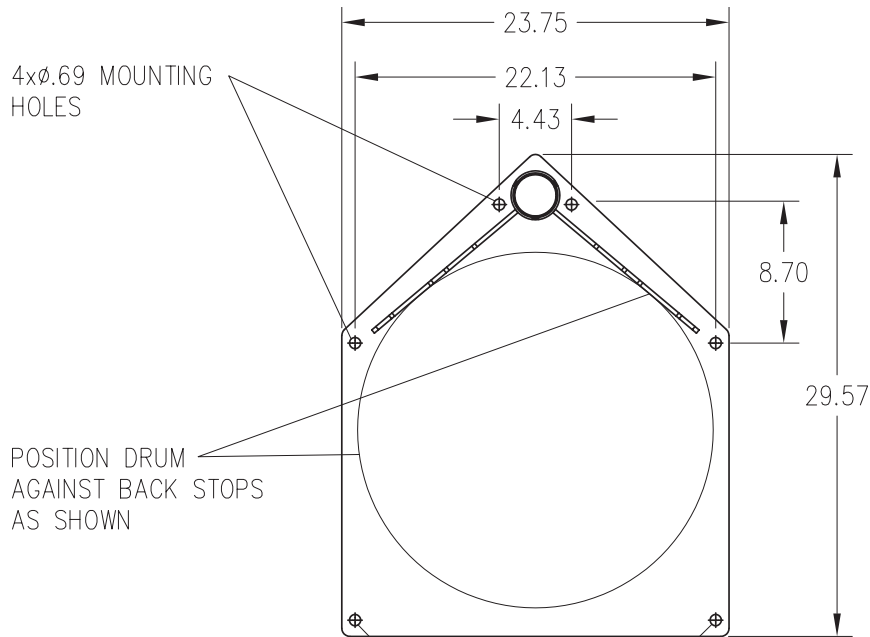

Illustration 3



OPERATING CONTROLS (See Illustrations 3, 5 & 6)

Hoist Control Valve (item 10): Three position air valve used to raise and lower the pump into and out of the drum. When the handle is moved up, the hoist will raise. When placed in the neutral position, with handle level with floor, hoist will stop and hold position. When the handle is placed in down position, the hoist will lower the pump into the drum.

Air Assist Push Button (item 17): Two way air valve used to force air under the follower assembly to assist in lifting the pump and follower from the drum. Used in conjunction with the Hoist Control Valve when removing the pump and follower from the drum.

Air Vent (item 21): Used to vent air trapped under the follower plate when the follower and pump is lowered into the drum. This valve should be open when the pump and follower are lowered into the drum. Air will escape from the valve as the follower is lowered into the drum. After the follower rests on top of the lubricant, the valve is closed by turning clockwise to seal the ball against the seat.

Hoist Regulator (item 44): Used to control the air pressure to the hoist only. The air pressure should be set to the necessary pressure required to raise the pump and follower. Too much pressure will cause the hoist to rise very quickly and may damage the hoist.

Pump Air Supply Valve (item 35 or 45): Used to control air to the air motor and pump assembly. When the pump is in operation this valve must be open to allow air to flow to the air motor. When servicing, relieving pressure, or operating the hoist, this valve must be closed to stop air motor and pump operation when the pump is removed from the drum.

OPERATION

1. Before operating, insure that the hoist is securely fastened to the floor. All connecting bolts must be tightened securely. Air connections and tube fittings are all tight and leak proof. Fluid connections are tight and leak proof.
2. All fluid and air hoses are to be connected as required.

Installing a Material Drum:

3. Adjust the hoist regulator, item 44, to about 30 PSIG. Move the Hoist Control Valve (item 10) to the raise position to lift the pump clear of the rim of the drum. Adjust the hoist regulator as required to a pressure high enough to raise the pump clear of the drum with out rapid uncontrolled rising of the pump. Move the Hoist Control Valve to the neutral position to hold the pump in position.
4. Position the drum of lubricant on the mounting base, item 8, so that the drum rests against the two gussets on the back side of the base. (See Illustration 3.)
5. Adjust, if necessary, the location of the pump support, (item 29 or 53) to center the follower assembly over the top of the drum. Tighten the bolts, (item 4) if an adjustment was made.

6. Open the Air Vent (item 21) to allow air to vent from below the follower as the follower is lowered into the drum.
7. Move the Hoist Control Valve (item 10) to the down position and guide the follower into the drum of lubricant. As the follower is lowered into the drum, air will vent from the vent valve. Continue to lower the pump and follower into the drum until it stops. If lubricant appears at the Air Vent, close the Air Vent, (item 21).
8. Leave the Hoist Control Valve in the down position at all times except when removing the drum from the drum.
9. Turn on the Pump Air Supply Valve (item 35 or 45) and adjust the air pressure to the air motor and pump tube assembly to prime the pump as required. See the owner's manual for the air motor and pump tube.
10. While in operation, as the pump removes material from the drum, the pump will continue to drop into the drum, following the level of material down to the bottom of the drum. Note that no air pressure used to exert force on the pump hoist to force the follower into the drum.

Removing a material drum:

11. When the pump follower reaches the bottom of the drum and drum replacement is necessary the pump may be removed from the drum as follows. Close the Pump Air Supply Valve (item 35 or 45).
12. Move the Hoist Control Valve (item 10) to the raise position, and press the Air Assist Push Button, (item 17), at the same time. Hold the base of the drum into the slots formed in the gussets on the mounting base with one foot while raising the pump from the drum. Modulating the Hoist Control Valve may be necessary to work the follower out of the drum. If the follower hangs up at the drum chimes, it may help to allow the drum to rise off the base slightly and allow the Air Assist to force the drum off the follower.
13. When the follower reaches the top of the drum, release the Air Assist Push Button, and place the Hoist Control Valve in the neutral position to hold the pump in position while the drum is replaced.
14. After removing the drum, remove any grease from the bottom side of the follower in the area of the Air Vent check ball (item 23), so that grease is not forced on top of the follower when placing the follower back into the lubricant.

**MODEL NOS. 2710 & 2740
PUMP & HOIST ASS'Y
MODEL NOS. 274680 & 274681
400 LB. DRUM SIZE AIR OPERATED, MANUALLY CONTROLLED**



SERVICE

When service is required see the appropriate owner's manual for the pump, air motor or pump tube for the model in use. Service on the hoist is limited to the hoist air cylinder assembly and the follower assembly. All other hoist components are not serviceable items.

WARNING! Before any service is attempted it is important to disconnect the air supply to the pump and hoist unit and bleed off all material pressure from the pump outlet and attached hoses.

Air Cylinder Service

- The pump must be removed from the hoist to service the air cylinder assembly. Disconnect all air lines between the pump and hoist assembly. Disconnect the air line to the follower assembly. The pump and pump mount (item 29 or 53) and the follower assembly, can be removed as a unit from the pump support (item 56) by removing the four attachment hex bolts, and washers, (items 4, 5, & 6). Place the pump and follower on large sheet of clean paper or cardboard to keep follower clean.
- Loosen set screw (item 12), and remove tube cap (item 11) from upper support tube (item 15).
- Slide the upper support tube off of the lower support tube (item 18) and set aside.
- The seal, (item 20) is accessible and may be replaced by removing from the piston (item 19) and replacing with a new seal.
- Carefully inspect the condition of the upper support tube (item 15) before reassembly, checking for scratches or damage to the inside surface. Before re-assembly, apply a liberal coating of grease to the inside surface of the upper support tube (item 15), piston (item 19), and seal (item 20).
- Reassemble in the reverse order of disassembly. Check all tubing and connections for leaks.

Follower Service

- The follower must be removed from the bottom of the pump for service. The pump does not need to be removed from the hoist. To remove the follower, remove the pump and follower from the material drum. Remove the drum from the base of the hoist. Lower the pump and follower to the base on top of a piece of clean cardboard or paper. Place hoist control valve in neutral position.
- Disconnect the air line from the follower.
- Loosen the three hex screws, item 24, and slide the follower off the end of the pump tube. The follower may be tight due to the O-ring seals (item 25) around the pump tube.
- Place follower on clean flat surface with air vent and pump tube bushing facing the top side.
- Remove the 18 hex screws (item 26), three segment rings (item 27) and follower wiper ring (item 28)
- Inspect all components for wear or damage, replacing any damaged or worn components.

- Re-assembly is the reverse of the disassembly process. When installing the hex screws, item 26, take care not to tighten too tight. The screws only need to be tight enough to seal the wiper to the follower. There should be no deflection to the segment rings (item 27) when the screws are tightened.
- Check for leaks and test after re-assembly.

Air Vent Service

- The Air Vent, items 21, 22, and 23, may be serviced without removing the pump or follower from the pump. The pump and follower must be removed from the drum. Lower the pump and follower to the base on top of a piece of clean cardboard or paper. Place hoist control valve in neutral position.
- Remove the valve screw assembly (item 21) by turning counterclockwise.
- Remove the retaining ring (item 23).
- The ball can now be removed through the slots on the sides of the valve body.
- Inspect the ball for any signs of wear or damage. Replace as necessary. Clean and inspect the valve body and follower surfaces where the ball is seated. Repair or replace as necessary.
- Reassemble in the reverse order of disassembly. Do not tighten the valve screw too tightly. It should only be tight enough to form a seal. If tightened too tightly, damage to the ball may occur.

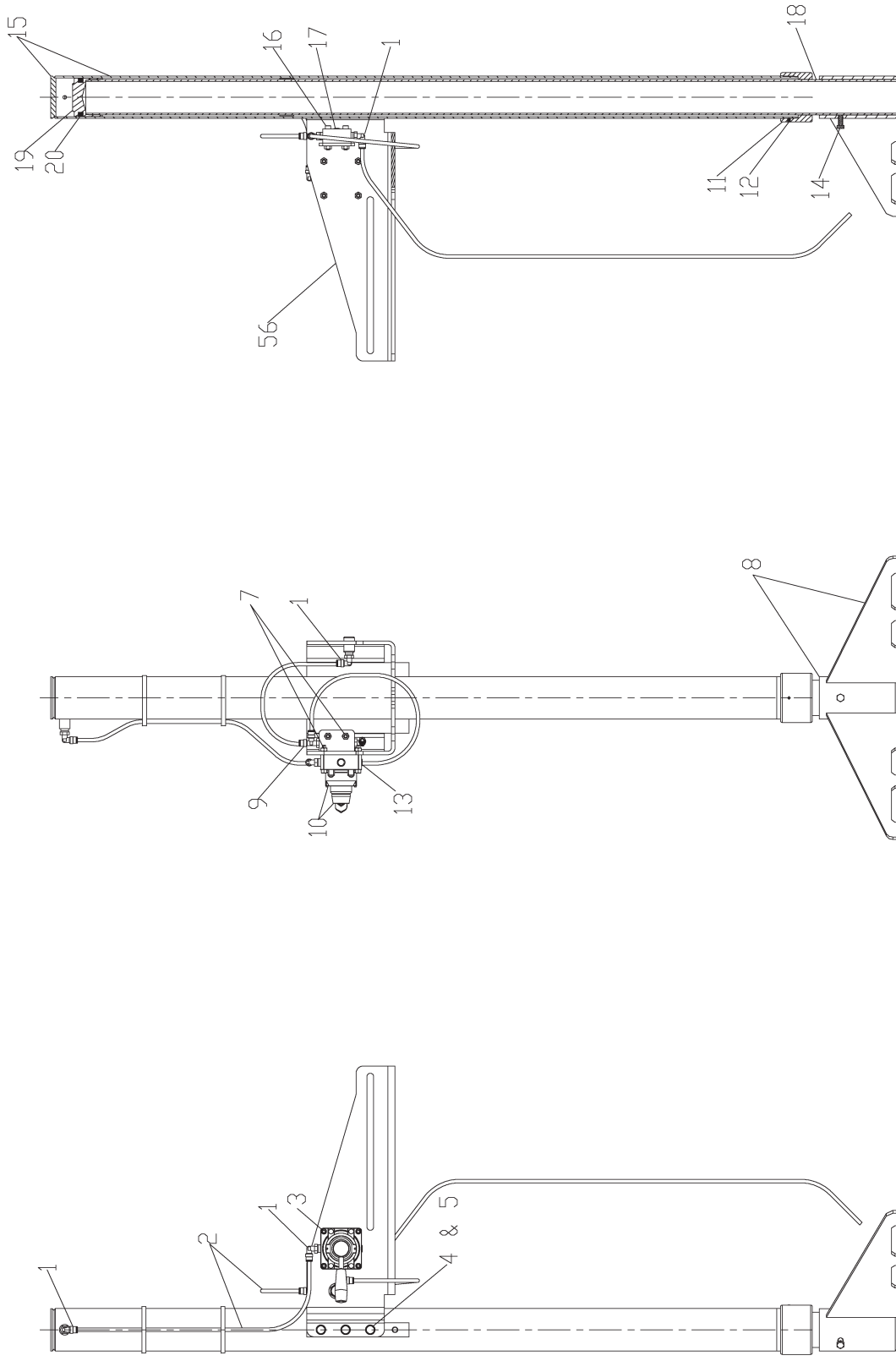

Illustration 4

MODEL NOS. 2710 & 2740
 PUMP & HOIST ASS'Y
 MODEL NOS. 274680 & 274681
 400 LB. DRUM SIZE AIR OPERATED, MANUALLY CONTROLLED



PowerMaster III
 Assembly Details

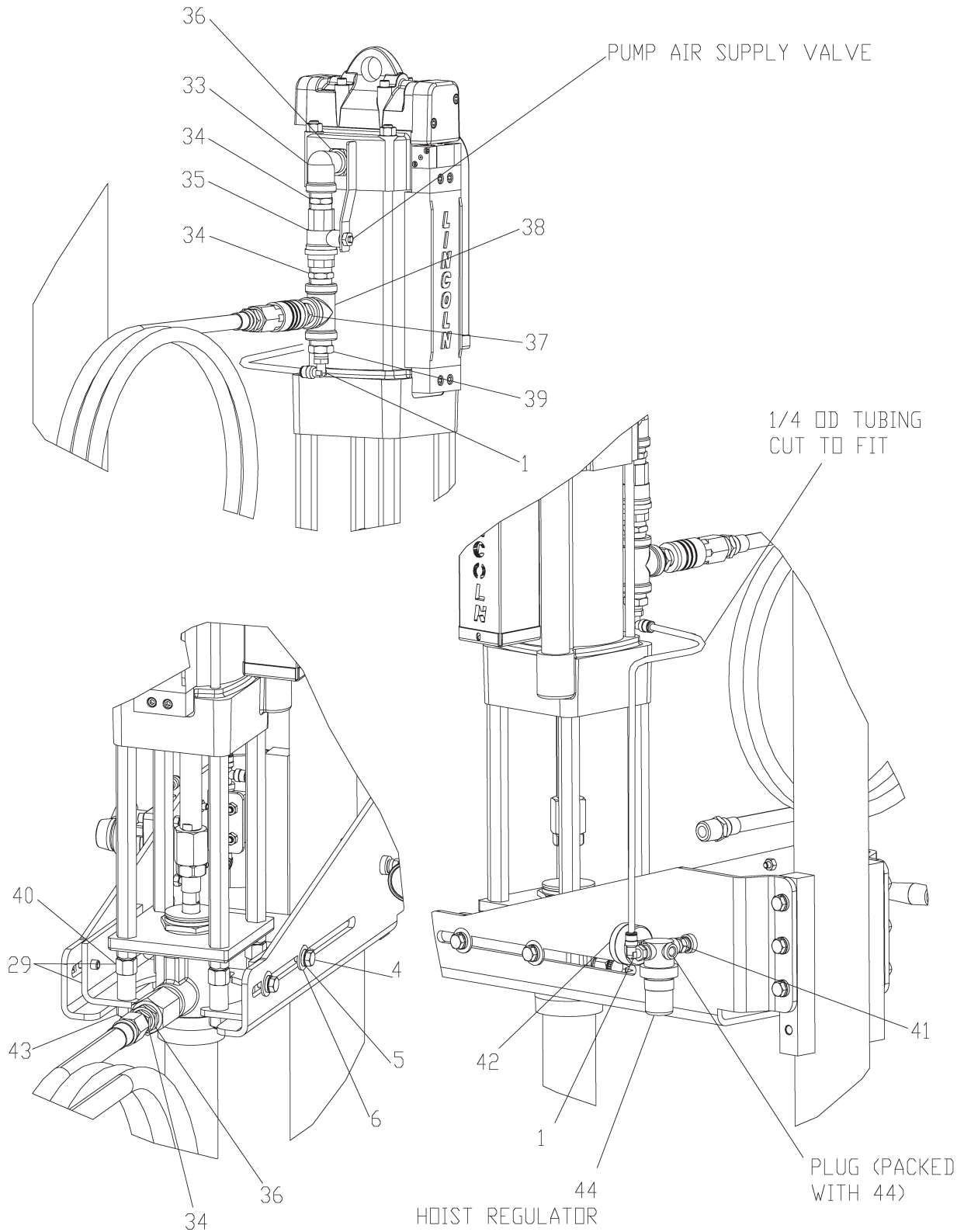

Illustration 5

**Series 40
 Assembly Details**

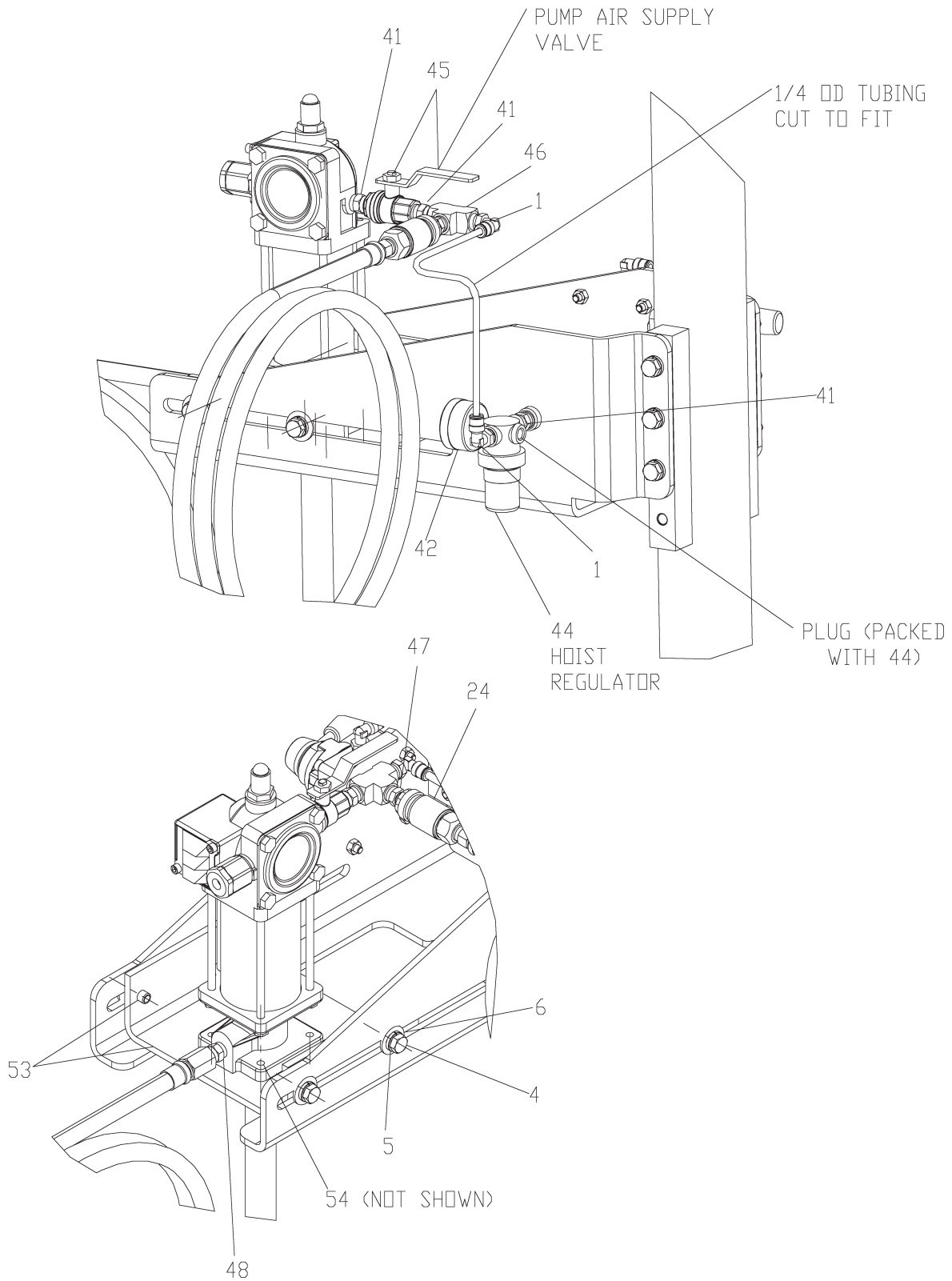

Illustration 6

MODEL NOS. 2710 & 2740
PUMP & HOIST ASS'Y
MODEL NOS. 274680 & 274681
400 LB. DRUM SIZE AIR OPERATED, MANUALLY CONTROLLED



Primer Assembly Detail

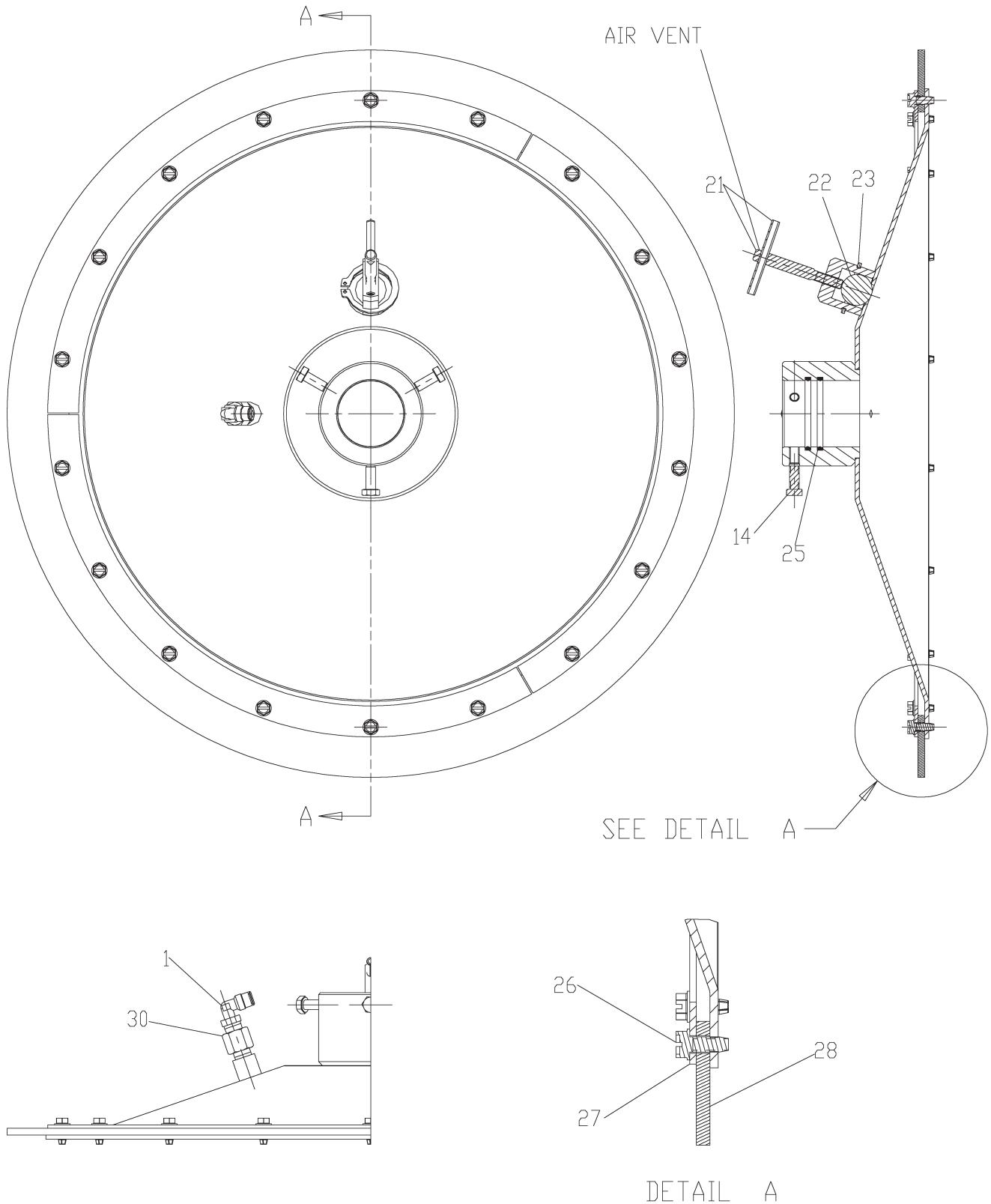

Illustration 7



MODEL NOS. 2710 & 2740
PUMP & HOIST ASS'Y
MODEL NOS. 274680 & 274681

400 LB. DRUM SIZE AIR OPERATED, MANUALLY CONTROLLED

Follower Adapter
Series 40 Pumps Only

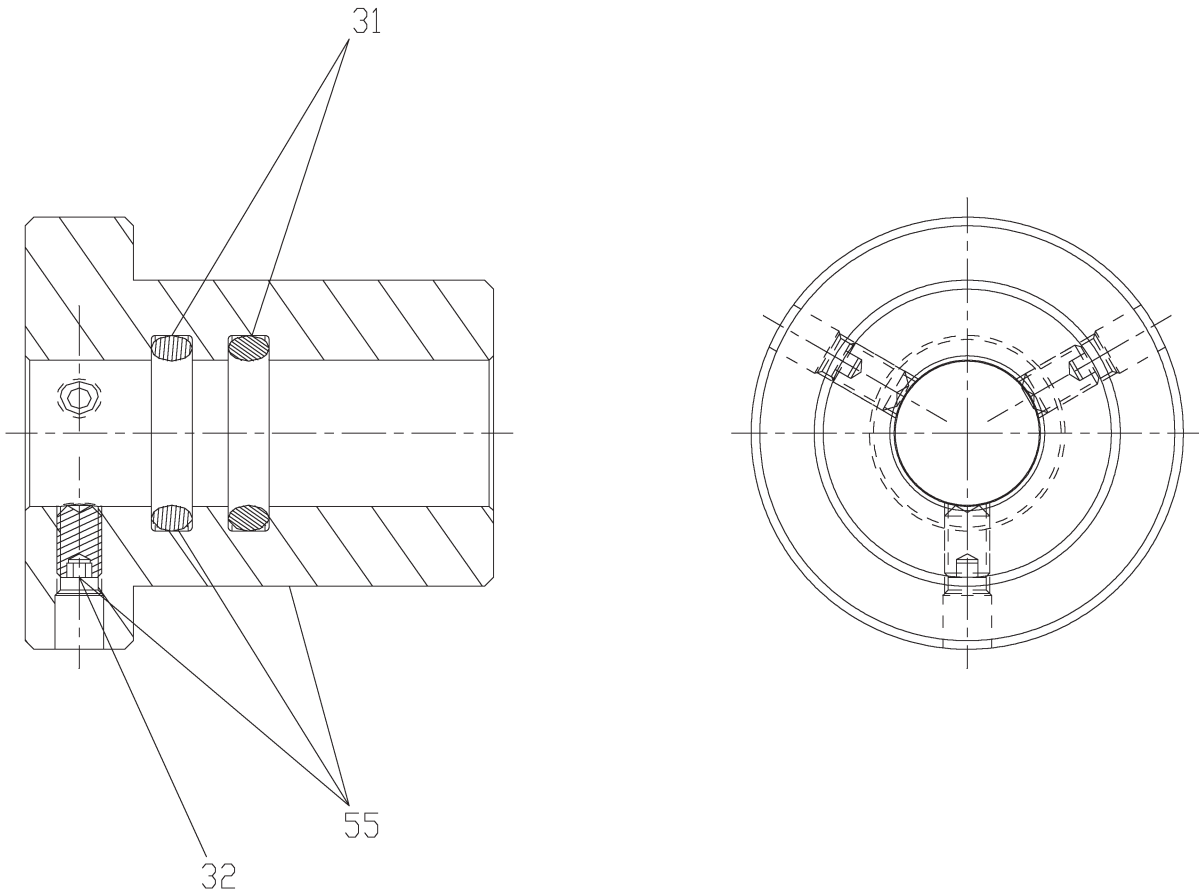

Illustration 8

**MODEL NOS. 2710 & 2740
PUMP & HOIST ASS'Y
MODEL NOS. 274680 & 274681
400 LB. DRUM SIZE AIR OPERATED, MANUALLY CONTROLLED**



PARTS LIST			USED ON	
ITEM	DESCRIPTION	PART NO	QUAN	
			2710	2740
1	1/4 OD X 1/4 NPTF (M) 90° ELL	247761	7	7
2	1/4 OD X .160 ID POLYURETHANE TUBING		AS REQ'D	AS REQ'D
3	1/4-20 x 1-3/4" SOC HD CAP SCREW	50779	4	4
4	3/8-16 X 1 HEX HD CAP SCREW	50044	10	10
5	3/8 SPLIT LOCK WASHER	66220	10	10
6	3/8 FLAT WASHER	48268	4	4
7	1/4-20 HEX NUT	51010	6	6
8	MOUNTING BASE	274661	1	1
9	1/4 MALE RUN TEE	274654	1	1
10	4-WAY AIR VALVE	237588	1	1
11	TUBE CAP	274719	1	1
12	#10-32 X 1/4" CUP POINT SET SCREW	50522	1	1
13	1/4 NPT PIPE PLUG	67359	1	1
14	5/16-18 X 3/4" HEX HD CAP SCREW	50016	6Ⓞ	6Ⓞ
15	UPPER SUPPORT TUBE	274666	1	1
16	1/4-20 X 1-1/2 SOC HD CAP SCREW	50051	2	2
17	2-WAY AIR VALVE	274682	1	1
18	LOWER SUPPORT TUBE	274664	1	1
19	PISTON	274663	1	1
20	PISTON SEAL	34327	1	1
21	VALVE SCREW ASSY	274651	1	1
22	1" BALL	274715	1	1
23	RETAINING RING	274650	1	1
24	AIR COUPLER	238208Ⓞ	NA	1
25	O-RING (NITRILE)	34337	2	2
26	1/4-20 X 5/8" TAPPING SCREW	274648	18	18
27	FOLLOWER SEGMENT	274644	3	3
28	WIPER RING (NITRILE)	34371	1	1
29	PUMP MOUNT ASSY, PM3 (INCL 4, 5, 6, 40, 43)	274733	1	NA
30	CHECK VALVE	274653	1	1
31	O-RING	274678	NA	2
32	5/16-18 X 1/2" CUP POINT SET SCREW	50525	NA	3
33	1/2 NPT ST. ELL	67074	1	NA
34	1/2 NPT HEX NIPPLE	11197	3	NA
35	1/2 NPT BALL VALVE	66084	1	NA
36	1/2 NPT X 3/4 NPT BUSHING	67171	2	NA
37	AIR NIPPLE	650108	1	NA
38	1/2 NPT TEE	67041	1	NA
39	1/4 NPT X 1/2 NPT BUSHING	12080	1	NA
40	EXTENSION ADAPTER	242328	4	NA
41	1/4 NPT HEX NIPPLE	10462	1	3
42	AIR PRESSURE GAGE	247843	1	1
43	1/2-13 UNC HEX NUT	51014	4	NA
44	MINI AIR REGULATOR	602003	1	1
45	1/4 NPT BALL VALVE	274771	NA	1
46	1/4 NPT TEE	67102	NA	1
47	AIR NIPPLE	238394	NA	1
48	HOSE CONNECTOR	10198	NA	2
49	1/2" X 84" AIR HOSE	273304Ⓞ	1	NA
50	3/8" X 84" HIGH PRESSURE HOSE	274727	1	NA
51	1/4" X 84" AIR HOSE	274728	NA	1
52	1/4 X 84" HIGH PRESSURE HOSE	236921	NA	1
53	PUMP MOUNT ASSY, SER 40 (INCL 4, 5, 6, 54)	274734	NA	1
54	1/4-20 X 9/16 HEX SCREW & WASHER ASSY	50060	NA	4
55	FOLLOWER ADAPTER, (INCL 31 & 32)	274679SⓄ	NA	1
56	PUMP SUPPORT	274669	1	1

Ⓞ Indicates change



MODEL NOS. 2710 & 2740
PUMP & HOIST ASS'Y
MODEL NOS. 274680 & 274681
400 LB. DRUM SIZE AIR OPERATED, MANUALLY CONTROLLED

Americas:
One Lincoln Way
St. Louis, MO 63120-1578
USA
Phone +1.314.679.4200
Fax +1.800.424.5359

Europe/Africa:
Heinrich-Hertz-Str 2-8
D-69183 Walldorf
Germany
Phone +49.6227.33.0
Fax +49.6227.33.259

Asia/Pacific:
51 Changi Business Park
Central 2
#09-06 The Signature
Singapore 486066
Phone +65.6588.0188
Fax +65.6588.3438

© Copyright 2007
Printed in USA

Web site:
www.lincolnindustrial.com