

Data Sheet

Wide-angle Spray Nozzle Model SDLMKR-EN (HSA-TD 31)
with Control Valve and Proximity Switch Part-No. 615-27990-2

3.3A-30008-A97

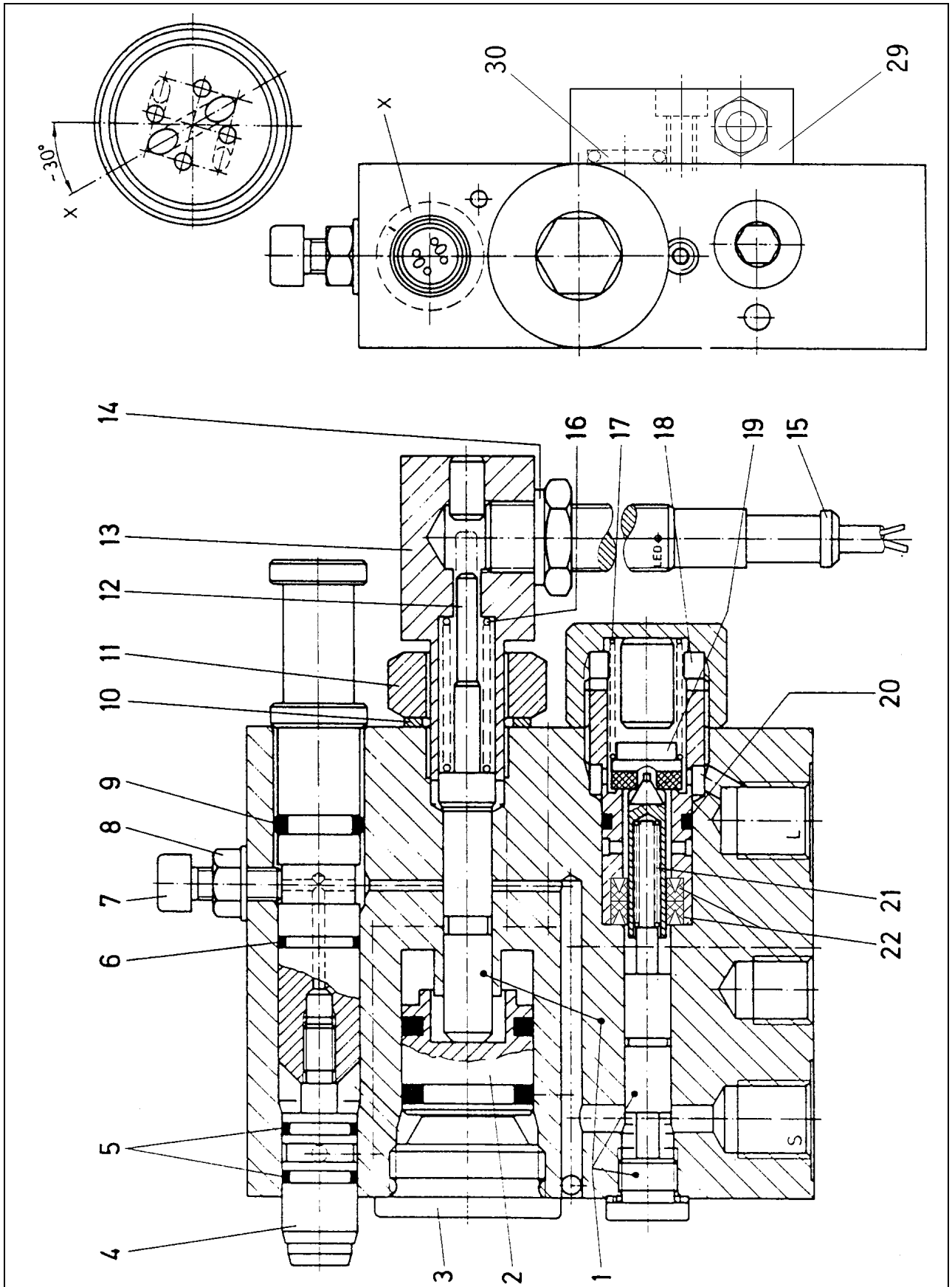

Data Sheet

Wide-angle Spray Nozzle Model SDLMKR-EN (HSA-TD 31)
with Control Valve and Proximity Switch Part-No. 615-27990-2



3.3A-30008-A97

Spare parts list

Item	Designation	Qty.	Part Number
1	spray nozzle block with precision-fitted piston consisting of: block valve piston control piston closure plug gasket	1	515-30902-1
2	air piston with 2 sealing rings	1	515-30889-1
3	closure plug M 26 x 1,5	1	303-17411-1
4	nozzle insert with holder includ. items 5, 6, 9	1	515-31698-1
5	O-ring 10 x 1,5	2	219-12228-5
6	O-ring 10 x 2	1	219-13064-3
7	hexagon socket head screw M 6 x 16	1	201-12019-9
8	hexagon flange nut M 6	1	207-12473-1
9	O-ring 10 x 2,5	1	219-12228-6
10	packing M 14	1	220-13653-1
11	hexagon nut M 14	1	207-12136-8
12	indicator pin	1	415-23621-2
13	adapter N	1	415-23625-3
14	packing M 12	1	220-13653-3
15	induct. proximity switch with 2 m long cable	1	234-13134-3
16	compression spring 6,8 x 1 x 35	1	300-17207-1
17	compression spring 12 x 1,25 x 34	1	300-17218-1
18	air valve assembly consisting of: spring guide U-cup sealing ring compression spring O-ring valve sleeve valve plate assembly compression spring stop closure cap	1	515-30903-1
19	valve plate assembly	1	515-31051-1
20	O-ring 11 x 2	1	219-12223-4
21	compression spring 4,5 x 0,9 x 15,6	1	218-12588-2
22	U-cup sealing ring 6 x 12 x 4 x 2	2	220-12512-8
29	collector assembly with screws and O-ring	1	515-32033-1
30	O-ring 8 x 2	1	219-12222-8